

**DRY PILLAR FIRE HYDRANT**  
(MODEL: 150-NFHQV-CD1 & 150-NFHQV-CD2)

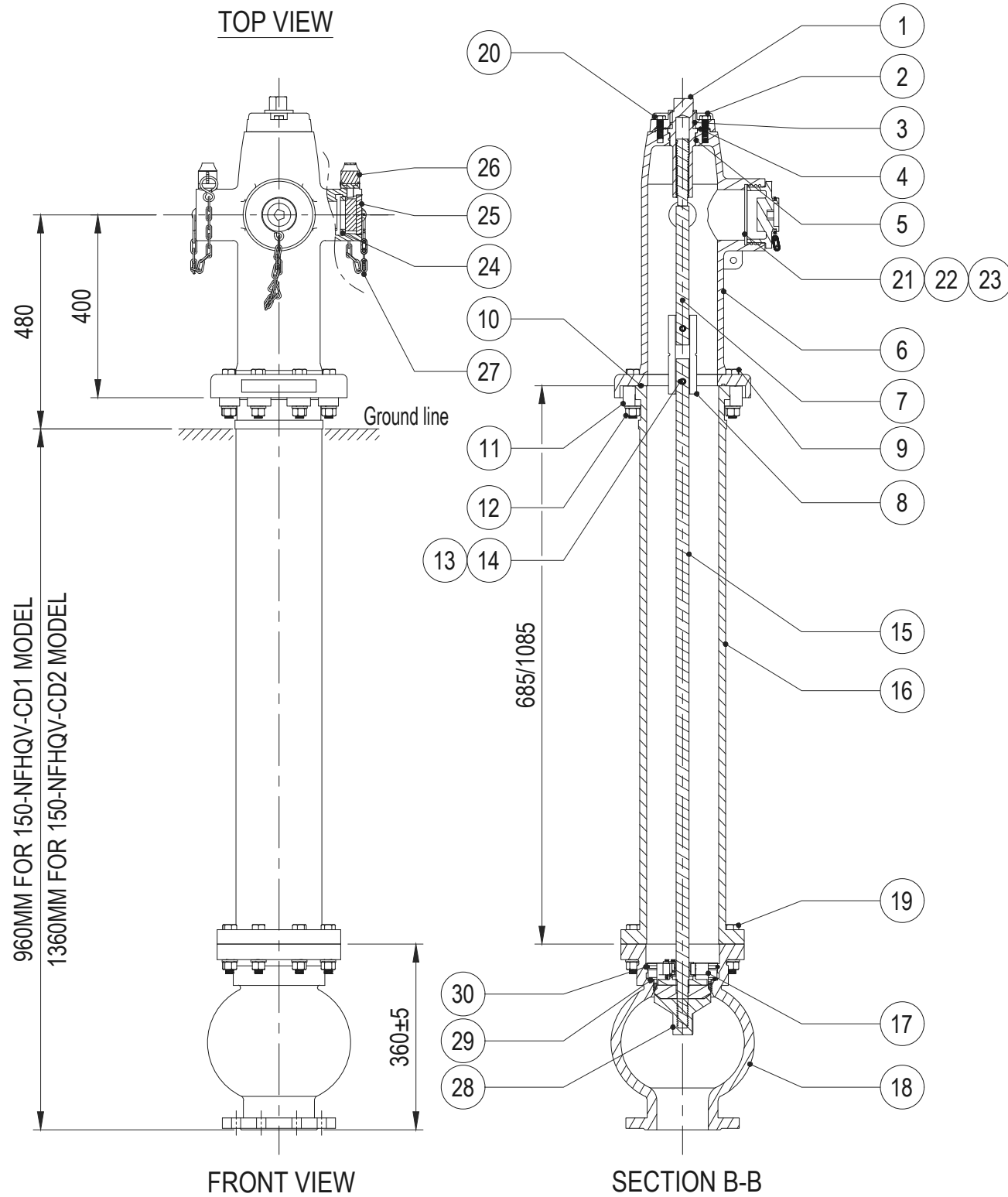

NOTES :-

1. ALL DIMENSIONS ARE IN mm. UNLESS OTHERWISE SPECIFIED

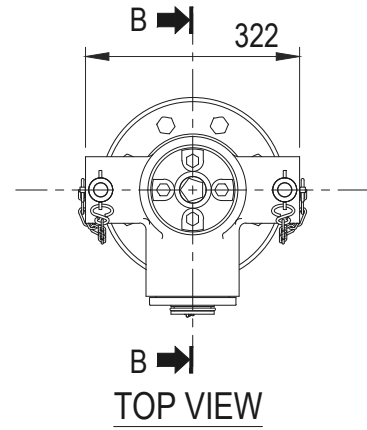

BILL OF MATERIALS		
SL. NO	DESCRIPTION	MATERIAL
1	PENTAGONAL OPERATING NUT	316
2	TOP COVER	EN-GJS-450-10
3	O RING	NBR
4	O RING	NBR
5	O RING	NBR
6	UPPER BODY	EN-GJS-400-15
7	UPPER STEM	316L
8	STEM COUPLING	316L
9	SCREW	316
10	O RING	NBR
11	CLAW	EN-GJS-450-10
12	NUT	316
13	SCREW	316L
14	NUT	316L
15	LOWER STEM ASSEMBLY	316L
16	BARREL	EN-GJS-400-15
17	BRASS NIPPLE ASSEMBLY	BRASS
18	LOWER BODY	EN-GJS-400-15
19	SCREW	316
20	SCREW	316
21	GASKET	NBR
22	CAP	EN-GJS-450-10
23	CHAIN	316
24	COUPLING GASKET	NBR
25	CAP	EN-GJS-450-10
26	HAND WHEEL ASSEMBLY	316
27	CHAIN	316
28	OBTURATOR ASSEMBLY	---
29	O RING	NBR
30	O RING	NBR

DESCRIPTION	SPECIFICATIONS	
MODEL	150 NFHQV-CD1 / 150 NFHQV-CD2	
INLET	DN 150 FLANGED TO BSEN 1092-2	
OUTLET	- 2NOS. 2 1/2" FEMALE INSTANTANEOUS OUTLET TO BS336 WITH CAP & CHAIN - 1NO. 4" FEMALE BSRT TO BS336 WITH CAP & CHAIN	
HYDRAULIC PRESSURE DETAILS	WORKING PRESSURE	16 BAR
	SEST TEST PRESSURE	17.5 BAR
	BODY TEST PRESSURE	24 BAR
STANDARD COMPLIANCE	BS EN 14384, BS 1074-1, BS 1074-2, BS 1074-6	
PAINT SPECIFICATIONS	EXTERNAL	
	UPPER BARREL	RED, PLASTIC POWDER COATING
	LOWER BARREL & VERTICAL FLANGE	BLACK, PLASTIC POWDER COATING
	INTERNAL	
	UPPER BARREL, LOWER BARREL & VERTICAL FLANGE	BLUE FBE COATING
MATERIAL	SPHEROIDAL GRAPHITE CAST IRON TO BS1563	
APPROVALS	LPCB	